

# C60

60/70/75/80

IC-PNEUMATIC    LPG/DIESEL  
13,500 / 15,500 / 16,500 / 18,000 lbs.  
(6000 / 7000 / 7500 / 8000 kg)

GEN 2



**CLARK**<sup>®</sup>  
**THE FORKLIFT**



- Foot steps with **traction plates** make entry/exit quick, easy and safe... from either side.
- The spacious **operator compartment** includes an easy to read color display. Real time information including error codes for the transmission and engine are shown in the LCD display.



## Highly Maneuverable, Easily Serviceable, Broadly Flexible, Extremely Dependable

With the combination of a 100 HP engine, fully automatic 3-speed transmission, wet disc brakes and rugged chassis design, the GEN2 C60 provides the **exceptional performance, maneuverability and durability** in its class that you've come to expect from CLARK.

# 8 metric tons

With a **capacity** of up to 18,000 lbs. the CLARK C60/70/75/80 is all the truck you will ever need.

- Nested Upright Rails, Overhead Guard Safety Bars (running parallel to operator's line of sight) and **dual primary cylinders with no center cylinder** expand the vision window and **reduce product damage**.

**Maximum Visibility + Minimum Fatigue = Ultimate Safety & Product Integrity**

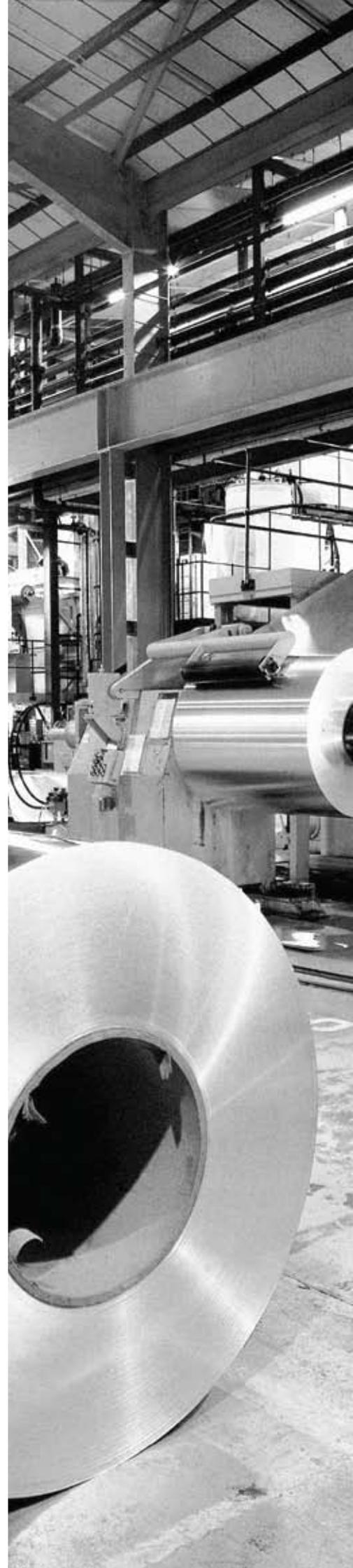

# C60 STANDARD FEATURES & BENEFITS



## PARKING BRAKE

### ■ Simple & Error Proof

- Hand operated parking brake activates brakes.
- Transmission disengages when parking brake is set preventing driving against park brake.

## WET DISC BRAKES ON ALL C60 MODELS

### ■ Enclosed & Oil Cooled

- For smooth, quiet operation.

### ■ Power Assist Design

- Low pedal effort reduces operator fatigue.

### ■ No Adjustments

- Longer service intervals mean less downtime.

### ■ 36 months or 10,000 hour warranty on brake discs



## THE POWER BEHIND THE PUNCH

### ■ 4.5 L Turbo Charged 100 HP Iveco Diesel Engine

- Provides exceptional output, torque & fuel economy.
- Cold start system, vertical exhaust and pre-cleaner come standard.
- Increased horsepower for better acceleration.

### ■ Field-Proven 4.3 L V-6 GM LPG Engine

- Built for smooth & quiet operation.

### ■ Auto Shut-Down

- Protects your investment in the event of excessive engine coolant, high transmission oil temperature or low engine oil pressure.

### ■ EPA Compliant

- Engines meet reduced emission and smoke levels.

## Available Equipment

- Wide range of upright options
- Double auxiliary valve
- Double hose adaptation
- Hydraulic control options
- Integral sidershifters
- Integral fork positioners
- Fork options
- Rear work light
- Strobe lights
- Reverse alarm
- Mirrors
- Full comfort operator cab
- Air conditioner
- Solid pneumatic tires
- Horizontal exhaust on Diesel



## "BUILT TO LAST" CHASSIS

- Heavy duty, welded, integral box frame assembly.
- Integral hydraulic & fuel tanks.
- Wrap-around side frame members for rigidity.
- Integral battery & tool box compartments.



### OPTIONAL OPERATOR CAB

#### ■ Maximum Visibility

- Unique OHG design minimizes vision obstruction of door pillars.

#### ■ 180° Fold & Lock Doors

- Door recesses within truck frame when locked open.



### RUGGED UPRIGHT AND CARRIAGE

#### ■ Maximum Visibility

- Lift cylinders, chains & hoses are all mounted within the rail profile.

#### ■ Hydraulic Cushioning Valves

- Silent staging reduces shock & vibration.

#### ■ Shimmable, Sealed & Canted Load Rollers

- Carriage has 8 rail rollers & 4 side thrust rollers.
- Maximize load distribution & reduce free play.



### "SMART SHIFT" TRANSMISSION

#### ■ Fully Automatic

- 3-Speed powershift transmission is standard on LPG & Diesel models.
- Operator friendly, automatic upshifting and downshifting.

#### ■ Modulated Shift Protection

- Smooth engagement, cushioned shifting.

#### ■ Electrically Controlled

- No adjustments required.

#### ■ Heavy Duty

- Robust components for longer life.

#### ■ Inching Valve

- Left brake pedal operation allows for precisely controlled travel speeds during high speed lifting.



### OPERATOR COMPARTMENT

#### ■ Fully Adjustable, Full Suspension Seat

- 2.4" vertical travel • 20° backrest adjustment range
- 6" fore / aft adjustment • Contoured for support
- Non-cinching, retractable seat belt

#### ■ Thick Molded Floor Mat

- Reduces vibration and noise level.
- Improves operator comfort.

#### ■ Protected Lights

- Headlights, brake & taillights and turn signals are mounted high to prevent damage.

#### ■ Tilt Steering Column

- Adjusts to suit operator & provides easy entry/exit.

# GENERAL DATA & STANDARD DIMENSIONS

## Upright Table

Maximum Fork Height in mm	Overall Height Lowered in mm	Overall Height Extended in mm	Free Lift in mm	Standard Tilt Spec B°/F°
------------------------------	---------------------------------	----------------------------------	--------------------	-----------------------------

### C60/70 Diesel / LPG and C75 LPG

#### Standard

98 (2500)	87.7 (2228)	143 (3634)	8.8 (223)	10/15
106 (2700)	91.7 (2328)	151 (3834)	8.8 (223)	10/15
118 (3000)	97.6 (2478)	163 (4134)	8.8 (223)	10/15
• 130 (3300)	103.5 (2628)	175 (4434)	8.8 (223)	10/15
138 (3500)	107.4 (2728)	182 (4634)	8.8 (223)	10/15
146 (3700)	111.3 (2828)	190 (4834)	8.8 (223)	10/15
157 (4000)	117.2 (2978)	202 (5134)	8.8 (223)	10/10
177 (4500)	127.1 (3228)	222 (5634)	8.8 (223)	10/10
197 (5000)	136.9 (3478)	241 (6134)	8.8 (223)	10/10
217 (5500)	146.8 (3728)	261 (6634)	8.8 (223)	10/10
236 (6000)	156.6 (3978)	281 (7134)	8.8 (223)	6/6
252 (6400)	164.5 (4178)	297 (7534)	8.8 (223)	6/6

### C60/70 Diesel / LPG and C75 LPG

#### Triple Stage

152 (3850)	91.1 (2315)	196 (4980)	47.8 (1213)	10/10
157 (4000)	93.1 (2365)	202 (5130)	49.7 (1263)	10/10
177 (4500)	99.7 (2533)	222 (5634)	56.3 (1431)	10/10
• 193 (4900)	105.0 (2667)	238 (6036)	61.6 (1565)	10/10
244 (6200)	122.0 (3099)	289 (7332)	78.6 (1997)	6/6
276 (7000)	132.5 (3365)	320 (8140)	89.1 (2263)	6/6
315 (8000)	145.6 (3697)	360 (9140)	102.2 (2595)	6/6

### C80 Diesel

#### Standard

91 (2300)	88 (2228)	135 (3434)	9.2 (233)	10/15
98 (2500)	92 (2328)	143 (3634)	9.2 (233)	10/15
110 (2800)	98 (2478)	155 (3934)	9.2 (233)	10/15
122 (3100)	103 (2628)	167 (4234)	9.2 (233)	10/15
• 130 (3300)	107 (2728)	175 (4434)	9.2 (233)	10/15
138 (3500)	111 (2828)	182 (4634)	9.2 (233)	10/15
150 (3800)	117 (2978)	194 (4934)	9.2 (233)	10/10
169 (4300)	127 (3228)	214 (5434)	9.2 (233)	10/10
189 (4800)	137 (3478)	234 (5934)	9.2 (233)	10/10
209 (5300)	147 (3728)	253 (6434)	9.2 (233)	10/10
228 (5800)	157 (3978)	273 (6934)	9.2 (233)	10/10
244 (6200)	164 (4178)	289 (7334)	9.2 (233)	6/6

### C80 Diesel

#### Triple Stage

144 (3650)	91 (2315)	192 (4881)	47.8 (1213)	10/15
150 (3800)	93 (2365)	198 (5031)	49.7 (1263)	10/10
169 (4300)	100 (2533)	218 (5535)	56.3 (1431)	10/10
• 185 (4700)	105 (2667)	234 (5937)	61.6 (1565)	10/10
236 (6000)	122 (3099)	285 (7233)	78.6 (1997)	6/6
268 (6800)	132 (3365)	317 (8041)	89.1 (2263)	6/6
307 (7800)	153 (3887)	356 (9041)	102.2 (2595)	6/6

\* Indicates Common Preferred Spec

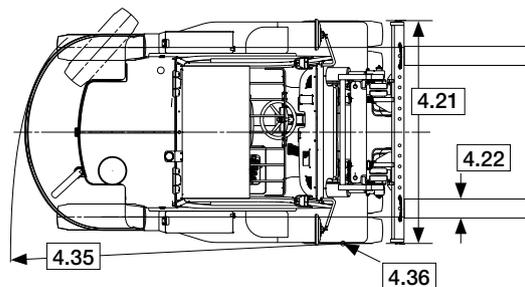
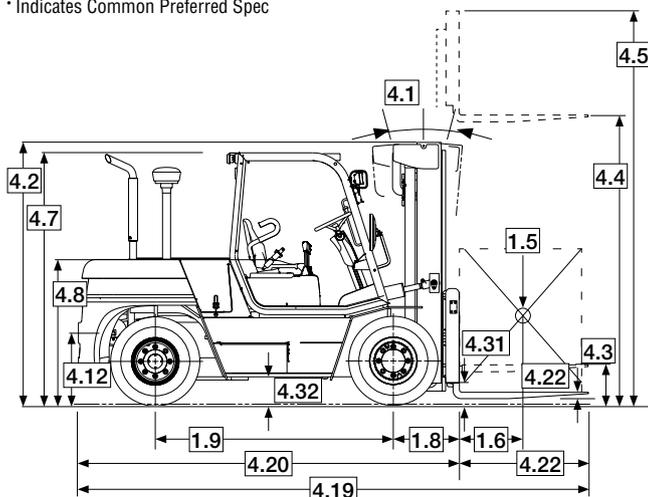

## Notes

Production engines and driveline components may vary in output and/or efficiency by  $\pm 5\%$ . The performance shown represents nominal values which may be obtained under typical operating conditions of a machine.

## ANSI/ITSDF and Insurance Classification

Standard truck meets all applicable mandatory requirements of Part III-ANSI/ITSDF B56.1 Safety Standard for Powered Industrial Trucks and Underwriters Laboratories requirements as to fire hazard only for D and LP classifications. For further information contact a Clark representative.

Users should be aware of, and adhere to, applicable codes and regulations regarding operator training, use, operation and maintenance of powered industrial trucks, including:

- ANSI/ITSDF B56.1
- NFPA 505, fire safety standard for powered industrial trucks - type designations, areas of use, maintenance and operation.
- Occupational Safety and Health Administration (OSHA) regulations that may apply.

Contact your authorized CLARK forklift truck dealer for further information including operator training programs and auxiliary visual and audible warning systems, fire extinguishers, etc., as available for specific user applications and requirements.

Specifications, equipment, technical data, photos and illustrations are based on information at time of printing and are subject to change without notice. Some products may be shown with optional equipment.

For corresponding data see Specification Chart

# STANDARD SPECIFICATIONS

Specifications	1.1	Manufacturer		Clark	Clark
	1.2	Manufacturer's designation		C60D	C70D
	1.3	Drive unit Diesel, L.P. Gas		Diesel	Diesel
	1.4	Operator type stand on / driver seated		driver seated	driver seated
	1.5	Load capacity / rated load	lbs (kgs)	13,500 (6000)	15,500 (7000)
	1.6	Load center distance		24 (600)	24 (600)
	1.8	Load center distance, center of drive axle to fork face	in (mm)	24.3 (617)	24.3 (617)
	1.9	Wheelbase	in (mm)	88.6 (2250)	88.6 (2250)
Weight	2.1	Service weight	lbs (kgs)	20,414 (9260)	21,230 (9630)
	2.2	Axle loading, loaded front / rear	lbs (kgs)	29,312 / 4329 (13,296 / 1964)	32,444 / 4217 (14,717 / 1913)
	2.3	Axle loading, unloaded front / rear	lbs (kgs)	8928 / 11,485 (4050 / 5210)	8666 / 12,563 (3931 / 5699)
Tires	3.1	Tire type, P = pneumatic, SE = solid pneu, C = cushion		P	P
	3.2	Tire size, front - dual wheels		8.25 x 15 - 14 PR	8.25 x 15 - 14 PR
	3.3	Tire size, rear		8.25 x 15 - 14 PR	8.25 x 15 - 14 PR
	3.5	Wheels, number front / rear (x = drive wheels)		4X / 2	4X / 2
	3.6	Tread, front	in (mm)	62.0 (1575)	62.0 (1575)
	3.7	Tread, rear	in (mm)	63.4 (1610)	63.4 (1610)
	Dimensions	4.1	Tilt of upright / fork carriage, back / forward, a / b	deg	10/15
4.2		Height, upright lowered	in (mm)	103.5 (2630)	103.5 (2630)
4.3		Freelift	in (mm)	8.8 (223)	8.8 (223)
4.4		Lift height	in (mm)	130.0 (3300)	130.0 (3300)
4.5		Height, upright extended	in (mm)	178.4 (4532)	178.4 (4532)
4.7		Height overhead guard	in (mm)	93.3 (2370)	93.3 (2370)
4.8		Seat height	in (mm)	52.0 (1320)	52.0 (1320)
4.12		Coupling height	in (mm)	18.7 (475)	18.7 (475)
4.19		Overall length	in (mm)	185.4 (4710)	187.8 (4770)
4.20		Length to face of forks	in (mm)	138.2 (3510)	140.6 (3570)
4.21		Width	in (mm)	83.7 (2125)	83.7 (2125)
4.22		Fork dimensions	in (mm)	2.4x5.9x48.0 (60x150x1200)	2.4x5.9x48.0 (60x150x1200)
4.23		Fork carriage		Pin Type	Pin Type
4.24		Fork carriage width	in (mm)	83.7 (2125)	83.7 (2125)
4.31		Ground clearance minimum, loaded	in (mm)	7.9 (200)	7.9 (200)
4.32		Ground clearance center of wheelbase	in (mm)	9.1 (230)	9.1 (230)
4.34		Right Angle Stack (add load length and clearance)	in (mm)	158.9 (4037)	160.1 (4067)
4.35		Outside turning radius	in (mm)	134.6 (3420)	135.8 (3450)
4.36	Inside turning radius	in (mm)	25.3 (643)	25.3 (643)	
Performance	5.1	Travel speed loaded / unloaded	mph (kph)	18.2 / 21.4 (29.3/34.4)	17.5/20.9 (28.1/33.7)
	5.2	Lift speed loaded / unloaded	fpm (m/s)	84.6/88.6 (0.43/0.45)	82.7/88.6 (0.42/0.45)
	5.3	Lowering speed loaded / unloaded	fpm (m/s)	88.6/84.6 (0.45/0.43)	88.6/84.6 (0.45/0.43)
	5.6	Max. drawbar pull loaded / unloaded	lbf (N)	14,102/13,609 (62,733/60,536)	14,197/13,628 (63,154/60,624)
	5.8	Max. gradeability loaded / unloaded	%	43.8 / 21.2	41.6 / 19.8
	5.10	Service brake		Wet disc brakes	Wet disc brakes
Drive Line	7.1	Manufacturer / Type		IVECO / N45-MNS	IVECO / N45-MNS
	7.2	Rated output per SAE J1349	HP / KW	99 / 74	99 / 74
	7.3	Rated speed	rpm	2300	2300
	7.4	No. of cylinders / displacement	/ cu in (liters)	4 / 274 (4.5)	4 / 274 (4.5)
8.2	Operating pressure for attachments	psi (Bar)	2030 (140)	2030 (140)	
8.4	Sound level, driver's ear	dB(A)	83	83	

# GEN2 C60/70/75/80

Clark	Clark	Clark	Clark
C80D	C60L	C70L	C75L
Diesel	LPG	LPG	LPG
driver seated	driver seated	driver seated	driver seated
18,000 (8000)	13,500 (6000)	15,500 (7000)	16,500 (7500)
24 (600)	24 (600)	24 (600)	24 (600)
24.3 (617)	24.3 (617)	24.3 (617)	24.3 (617)
98.4 (2500)	88.6 (2250)	88.6 (2250)	88.6 (2250)
22,839 (10,360)	19,902 (9029)	20,720 (9399)	21,036 (9542)
35,249 / 5227 (15,989 / 2371)	29,147 / 3986 (13,221 / 1808)	32,280 / 3873 (14,642 / 1757)	34,107 / 3463 (15,471 / 1571)
8893 / 13,946 (4034 / 6326)	8765 / 11,140 / 3976 / 5053)	8501 / 12,200 (3856 / 5543)	8629 / 12,407 (3914 / 5628)
P	P	P	P
8.25 x 15 - 18 PR	8.25 x 15 - 14 PR	8.25 x 15 - 14 PR	8.25 x 15 - 14 PR
8.25 x 15 - 18 PR	8.25 x 15 - 14 PR	8.25 x 15 - 14 PR	8.25 x 15 - 14 PR
4X / 2	4X / 2	4X / 2	4X / 2
62.0 (1575)	62.0 (1575)	62.0 (1575)	62.0 (1575)
63.4 (1610)	63.4 (1610)	63.4 (1610)	63.4 (1610)
10/15	10/15	10/15	10/15
103.5 (2630)	103.5 (2630)	103.5 (2630)	103.5 (2630)
8.8 (223)	8.8 (223)	8.8 (223)	8.8 (223)
130.0 (3300)	130.0 (3300)	130.0 (3300)	130.0 (3300)
178.4 (4532)	178.4 (4532)	178.4 (4532)	178.4 (4532)
93.3 (2370)	93.3 (2370)	93.3 (2370)	93.3 (2370)
52.0 (1320)	52.0 (1320)	52.0 (1320)	52.0 (1320)
18.7 (475)	18.7 (475)	18.7 (475)	18.7 (475)
200.6 (5095)	185.4 (4710)	187.8 (4770)	187.8 (4770)
153.5 (3895)	138.2 (3510)	140.6 (3570)	140.6 (3570)
83.7 (2125)	83.7 (2125)	83.7 (2125)	83.7 (2125)
2.8x7.1x48.0 (70x180x1200)	2.4x5.9x48.0 (60x150x1200)	2.4x5.9x48.0 (60x150x1200)	2.4x7.1x48.0 (60x180x1200)
Pin Type	Pin Type	Pin Type	Pin Type
83.7 (2125)	83.7 (2125)	83.7 (2125)	83.7 (2125)
7.9 (200)	7.9 (200)	7.9 (200)	7.9 (200)
9.1 (230)	9.1 (230)	9.1 (230)	9.1 (230)
172.9 (4392)	158.9 (4037)	160.1 (4067)	160.1 (4067)
148.6 (3775)	134.6 (3420)	135.8 (3450)	135.8 (3450)
29.4 (746)	25.3 (643)	25.3 (643)	25.3 (643)
17.0 / 20.0 (27.4 / 32.2)	18.2 / 19.5 (29.3 / 31.4)	18.0 / 18.8 (29.0 / 30.2)	17.6 / 18.4 (28.3 / 29.6)
76.8 / 88.6 (0.39 / 0.45)	86.6 / 96.5 (0.44 / 0.49)	82.7 / 96.5 (0.42 / 0.49)	76.8 / 96.5 (.039 / 0.49)
88.6 / 84.6 (0.45 / 0.43)	88.6 / 84.6 (0.45 / 0.43)	88.6 / 84.6 (0.45 / 0.43)	88.6/84.6 (0.45/0.43)
14,043/13,525 (62,468/60,164)	13,448 / 5247 (59,820 / 23,340)	14,109 / 5093 (62,762 / 22,653)	13,360 / 5159 (59,428 / 22,948)
37.6 / 19.2	41.0 / 21.4	42.2 / 20.0	38.4 / 20.0
Wet disc brakes	Wet disc brakes	Wet disc brakes	Wet disc brakes
IVECO / N45-MNS	GM / 4.3 L Vortec	GM / 4.3 L Vortec	GM / 4.3 L Vortec
99 / 74	93 / 69	93 / 69	93 / 69
2300	2400	2400	2400
4 / 274 (4.5)	6 / 262 (4.3)	6 / 262 (4.3)	6 / 262 (4.3)
2030 (140)	2030 (140)	2030 (140)	2030 (140)
83	83	83	83

## ***& Don't Forget...*** **Safety Starts With You!**

### **Before operating a lift truck, an operator must:**

- Be trained and authorized
- Read and understand operator's manual
- Not operate a faulty lift truck
- Not repair a lift truck unless trained and authorized
- Have the overhead guard and load backrest extension in place
- Perform daily inspections

### **During operation, a lift truck operator must:**

- Wear a seat belt
- Keep entire body inside truck cab
- Never carry passengers or lift people
- Keep truck away from people and obstructions
- Travel with lift mechanism as low as possible and tilted back
- Allow safe stopping distance and come to a complete stop before leaving operator compartment

### **To park a lift truck, an operator must:**

- Completely lower forks or attachments
- Shift into neutral
- Turn key off
- Set parking brake



- We don't just build forklifts. As a company, we are also focused on providing our customers with the best possible technical service support and aftermarket parts available.
- Even though our business starts with a quality, cost-effective product, our organization understands that it is the support and services we provide after the sale that help keep your business running at peak efficiency.
- **THE CLARK PartsPRO® SYSTEM** is our industry-leading electronic parts and service documentation tool that provides dealers with a quick and accurate method of identifying parts for every CLARK forklift built since 1961. PartsPRO® ensures the availability of the most current technical information and has the unique capability to create parts manuals specific to your mixed CLARK fleet, making it simple to positively identify and order the correct part(s) from your local CLARK dealer. The right CLARK part — The First Time, Every Time.
- **UNRIVALED PARTS SUPPORT** Our Aftermarket Distribution Center provides parts to over 250 North American CLARK dealers and many international dealers. This CLARK operated 184,000 square foot facility is dedicated to supporting the CLARK models built over the last 90 years. This facility is focused on providing excellent off-the-shelf availability, quality parts, quick response time and competitive pricing.

**DEPENDABLE PARTS = DEPENDABLE TRUCKS**



**BUILT TO LAST.®**



**CLARK MATERIAL HANDLING COMPANY**

North American Headquarters  
700 Enterprise Drive • Lexington, KY 40510  
866-252-5275 • [www.clarkmhc.com](http://www.clarkmhc.com)

**GEN2 C60/70/75/80**

59-894-0333 Printed in USA rev0308CR5M

© 2008 CLARK Material Handling Company